

Position

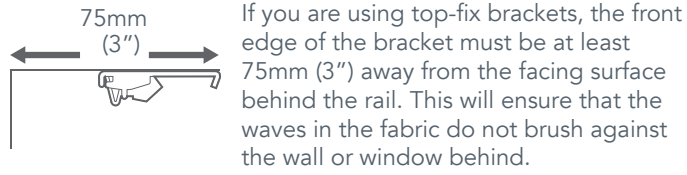
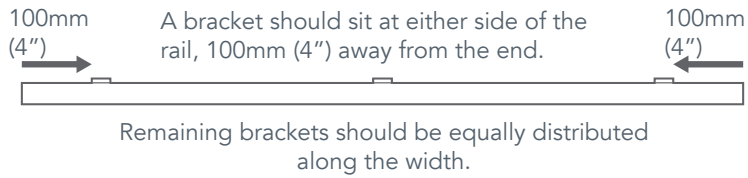

Install the brackets

Face Fix Bracket

Use two screws to fix the bracket onto the facing surface.

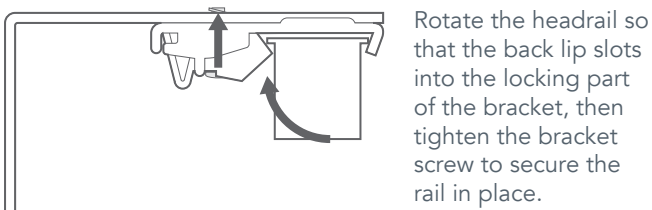
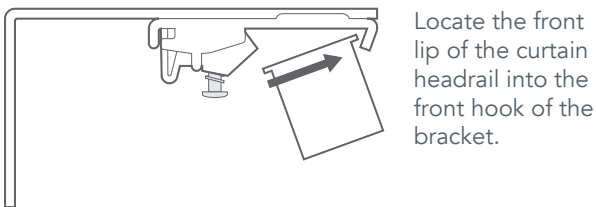
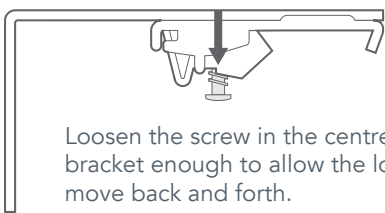
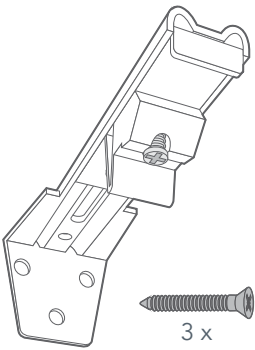

Top-Tip:

The depth of the bracket is adjustable, allowing the track to be closer to or further from the fixing surface. Loosen the screw at the back of the top section, slide the section backwards or forwards to adjust, then tighten the screw to lock.

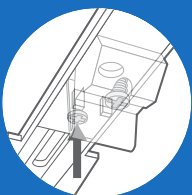

Top Fix Bracket

Start by clipping the brackets onto the rail, spaced out as above.

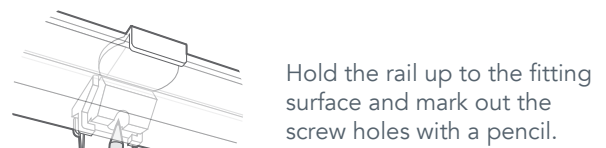
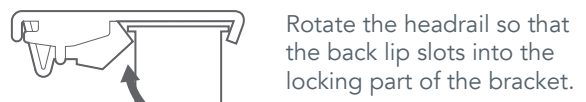
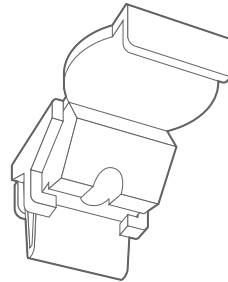

Put the rail safely to one side and drill holes where you marked out the brackets, then insert a rawl plug into each hole.

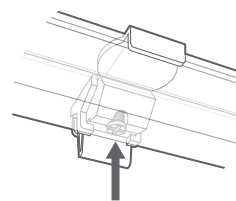

Use a single screw for each bracket, through the centre hole in the top of the bracket.

Hang your curtains

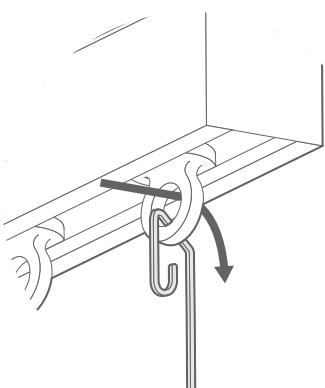

Insert the hooks into the plastic eyelets in the headrail.

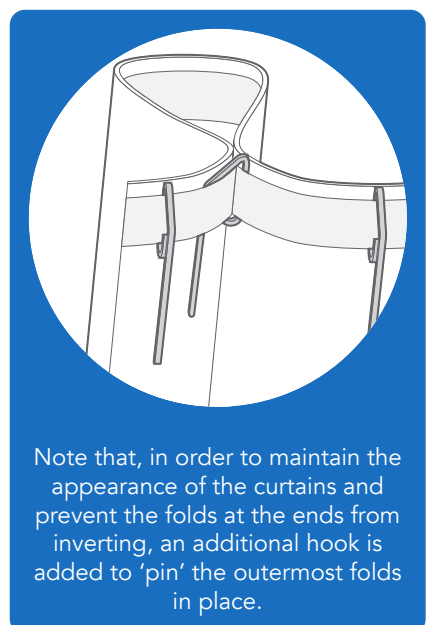
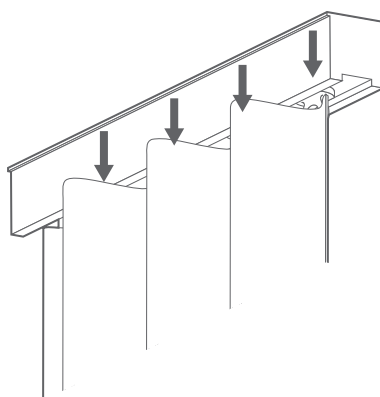

Note that, in order to maintain the appearance of the curtains and prevent the folds at the ends from inverting, an additional hook is added to 'pin' the outermost folds in place.